

Schlüsselbauer Technology GmbH & Co. KG, 4673 Gaspolthofen, Austria

Haba-Beton Equips Third Plant with Monolithic Manhole Base Production

■ Christian Weinberger, Schlüsselbauer Technology GmbH & Co. KG, Austria

In 2021, another Perfect manhole base production system developed by Schlüsselbauer Technology, was brought into operation in Nussdorf, in one of the two Austrian plants of the family group Haba-Beton. Haba-Beton now has three sites equipped with the technology used to manufacture custom-made monolithic concrete manhole bases. Perfect manholes have been in production in the Bavarian village of Teising since 2005, and in the eastern German municipality of Großsteinberg since 2011, and most recently in Nussdorf, Lower Austria, in 2021.

As the first German manufacturer of monolithic Perfect manhole bases on an industrial scale, Haba-Beton has been making its mark on the market for innovative wastewater technology over recent years. In addition to optimal flow characteristics in the Perfect concrete manhole, engineers working on Haba-Beton manhole bases particularly appreciate their consistent product quality. The homogeneous concrete quality of the monolithic components allows for only a shallow depth of water penetration. The leakproof concrete structure ensures a high degree of both mechanical and chemical resistance. If the component is subject to higher requirements, an alternative product is available in the form of manholes made of high-performance concrete, which is extremely durable and



The Haba-Beton site in Nussdorf. Haba-Beton has been running this pipe and manhole production plant near Vienna since 1998.

satisfies all of the conditions that arise in conventional wastewater systems.

Production at the Nussdorf location is initially intended for a daily output of approx. 40 manholes, which is approximately half of the system's total capacity for manufacturing EPS channels. This gives the plant manager the flexibility to choose between preparing the necessary channels that is required each day, or manufacturing the channels in two-day intervals for use over the next two days. Either way, the staff involved is supported by the planning software, and they simply have to



Complete channels are manufactured by means of simple cutting and gluing.



Impressions of the Perfect production at Haba-Beton Nussdorf.

keep track of their daily production schedule. They can even easily manufacture different channels simultaneously by following the simple instructions at the individual workplaces. The system displays the next work step, and the precision of the finished channel is inspected by means of laser projection.

Perfect Manhole - A Key Component of the Haba-Beton Quality Offensive

To create the pipe connections, gaskets firmly anchored in the manhole concrete have become the norm for many types of pipe in recent years. The "integrated" gaskets are pre-installed on EPS moulded parts and delivered to the precast

plant, and can simply be glued to the prepared channel components. The increasing use of integrated gaskets is another aspect of Haba-Beton's quality offensive in the manholes product segment. It means that gaskets cannot go missing on their way to the site, and it eliminates faulty installation or confusion between different pipe connections of the same nominal diameter. The design of the manhole structure, including the types of pipe connection, angle, and incline, is labeled clearly. In addition to data related to the construction site, all the workers involved in the precast plant and on the construction site always have all the relevant product information at their disposal. The user-friendly component is complete with offset anchors, which are concreted into the contact surface on the manhole.

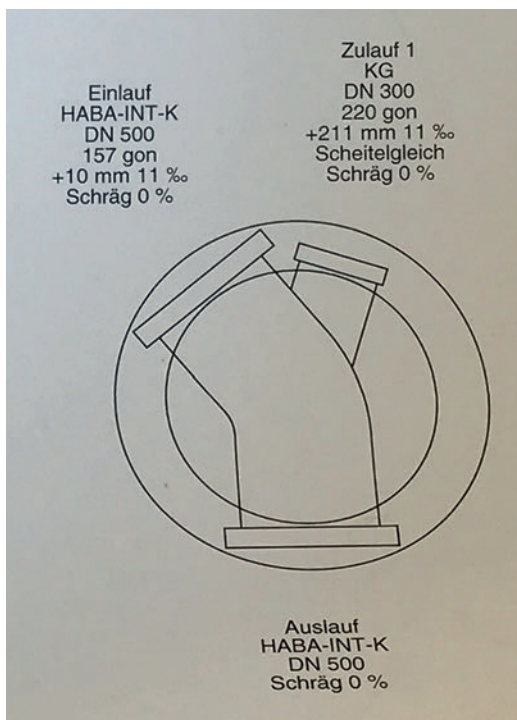

Even for complicated components, the relevant product data is clearly displayed on an adhesive label.

CONCRETE PIPES AND MANHOLES

Among all the enthusiasm for the new production technology, there is one clear priority for Alfred Kaiser, plant manager of Haba-Beton in Nussdorf: "We have to be able to meet our customers' requirements efficiently, while continuing to meet all of the quality requirements - every single day. It was clear that as the Perfect production system has already been operating reliably at two other Haba-Beton locations for years now it could be implemented here in Austria too." While the handling of filled moulds is fully automated at the two locations in Germany by means of an automatic crane, the casting moulds in Nussdorf are operated in a stationary manner. The concrete is brought to the moulds in buckets carried by an indoor crane. Once they have set, the products are demoulded using an indoor crane with a hydraulic turning gripper, and placed on a chain conveyor for transportation out of the production hall. Before that, the EPS negative channel is demoulded and processed using a shredder for recycling.

Saving On Concrete and Transport Weight in Special Components DN1000 and DN1200

For the connection of large nominal pipe diameters, moulds are used for the DN1000 and DN1200 nominal shaft diameters, which have the necessary wall thickness for large pipes, but also partially reduce the wall thickness in the further component circumference. A mould with a nominal diameter of DN1000 has a wall thickness of 360 mm, while DN1200 has a wall thickness of 420 mm.

Pipe connections up to a connection diameter of 1000 mm can be made in these heavy components using the standard range of Perfect moulded parts.



Manholes with integrated gaskets as a key part of the Haba-Beton quality offensive

cordes

Sealing systems for sewer construction

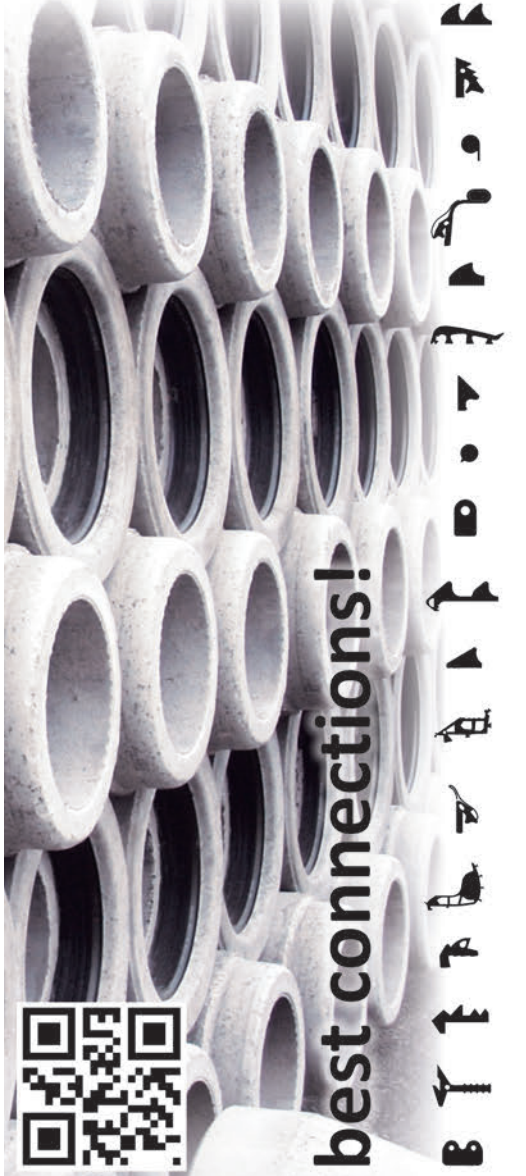

Synonymous with high-quality components in drainage technology
 - Haba-Beton Perfect manhole bases can be manufactured with standard C40/50 concrete or with high-performance concrete.

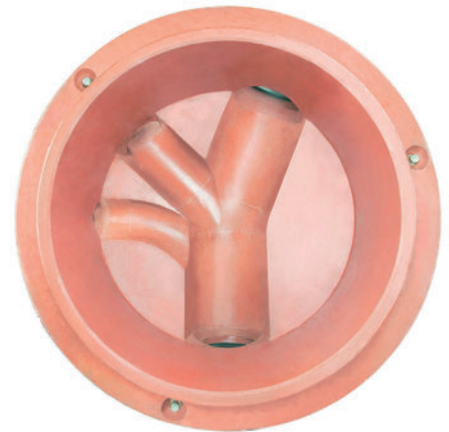

The Perfect production system from Schlüsselbauer Technology has already been installed more than 60 times around the world since 2005. Local requirements can be ideally met with a variety of moulded parts in the metric and imperial manhole ranges. And the range of moulded parts is constantly being expanded in line with specific customer requirements. The range of manhole diameters for which the moulded parts and planning software are designed starts at DN600 and extends to DN2100. The system's flexibility is particularly brought to bear with large shaft diameters. With the moulded parts, which have already undergone material optimization, channels can easily be made longer. The precise angle and incline of the channels and inlets are formed in one consistent system, even for manholes with large diameters.

The two owners, Franz and Johann Bartlechner, unanimously explain their decision to invest in another Perfect manufacturing system: "For us, it's not just the physical proximity to the outfitter Schlüsselbauer Technology or our own role as one of the first Perfect manufacturers in the world, it is first and foremost the fact that there are still no other comparable systems with which we could produce the quantity and quality of manhole components that we need to serve our customers every day." ■



Schlüsselbauer sponsored the free download possibility of the pdf of this article for all readers of CPI. Please check the website www.cpi-worldwide.com/en/channels/schuesselbauer or scan the QR code with your smartphone to get direct access to this website.



FURTHER INFORMATION



Johann Bartlechner KG
 Langswert 72, 84518 Garching an der Alz, Germany
 T +49 8634 6240
www.haba-beton.de



Schlüsselbauer Technology GmbH & Co. KG
 Hörbach 4, 4673 Gaspoltshofen, Austria
 T +43 7735 7144
www.sbm.at



Two Haba-Beton sites in Germany have been producing Perfect manhole bases on an industrial scale since 2005 and 2011.